



GS SERIES
SIDE MOUNTED LEMINATED FILTER

www.minderwater.com.au
sales@minderwater.com.au

Our Products
Your Future.

*All specifications are only for references. Actual product performance may vary due to external factors.
Product's colours and specifications are subjected to change without prior notices.*

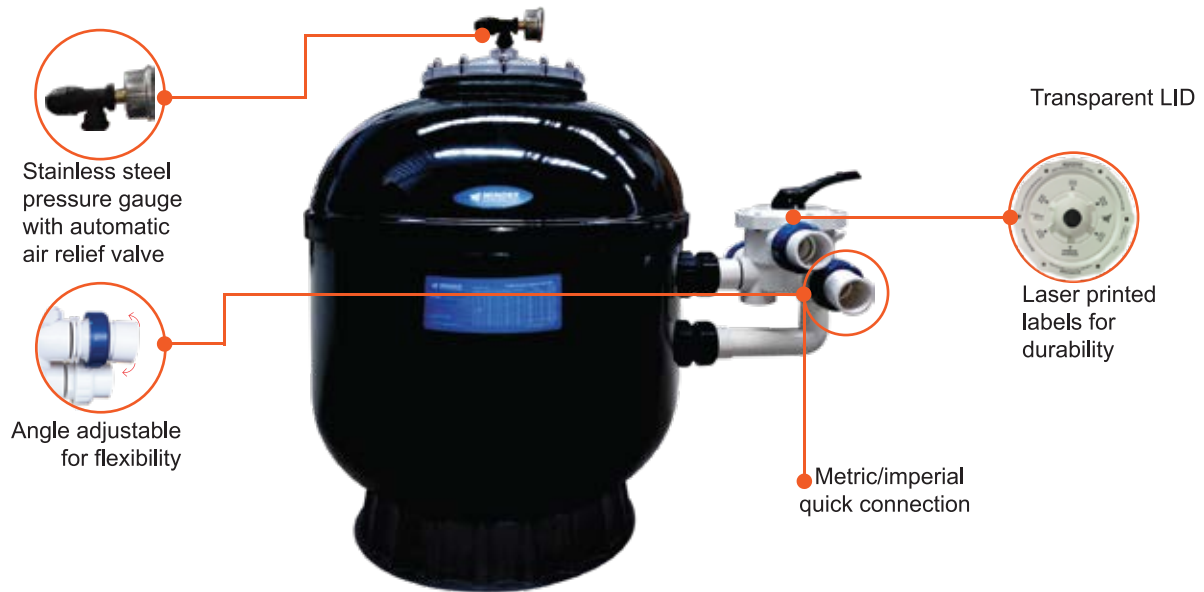

Minder GS Series filter is Minder's Innovative and elegant design for domestic filtration system. The series comes with top-mounted multiport valve with either 1.5" or 2.0".

Features & Advantages

- 100% factory tested according to international standard and MINDER improved standard.
- Automatic air release valve enables automatic release of trapped air during filter operation or negative pressure during water drain.
- Easy to use durable 6-ways multiport valve fitted with angle adjustable union to prevent pipe breakage during handling
- Materials used are dependable and suitable for all-weather performance
- Dual layers of fibreglass inner shell with UV resistant gel-coated surface allows the filter to work under direct sunlight
- 5-10 years life-time

Warranty

Multiport valve & fittings	1 year
Filter Tank	1 year



Operating Limits

Model	2.5bar
Maximum water temperature	43°C
Operating Pressure	2.5bar
Maximum Pressure	4.0bar

Optional Components

- Vinyl-ester internal coating
- FilterClean™ – Chemical Tablet Feeder

Model	Code	Multiport Valve Union Size		Tank Ø	Filtration Area	Designed Velocity	Max Flow Rate		Media Depth Bed	Silica Sand (kg)	
		2.5bar	Imperial	Metric	mm	m ²	m ³ /h/m ²	m ³ /h	lpm	mm	1-1.2mm
VS1.5 multiport valve with union size 1.5" / 50mm											
GS18	70117		1.5"	50mm	450	0.16	48	8	133	300	40
GS21	70118				550	0.22		12	200	340	85
GS25	70119				650	0.33		16	267	420	155
GS28	70120				700	0.38		19	317	460	210
VS2.0 multiport valve with union size 2.0" / 63mm											
GS28B	70736		2.0"	63mm	700	0.38	48	20	333	460	210
GS32	70122				800	0.50		25	417	500	250
GS36	70123				900	0.64		30	500	570	350
GS40	70737				1000	0.79		33	550	610	600
GS44	70738				1100	0.98		38	633	660	900

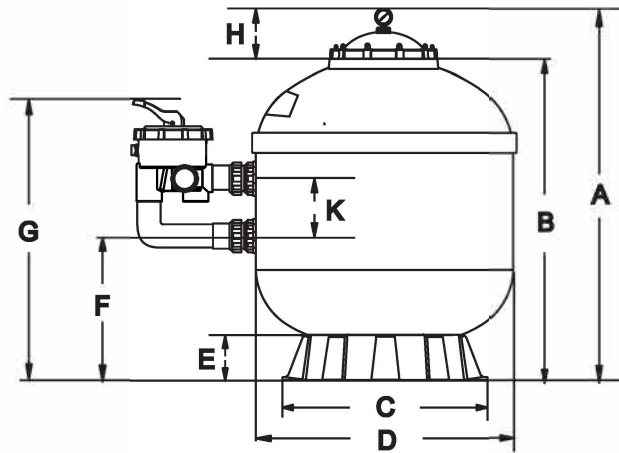

Dimensions

Model	A	B	C	D	E	F	G	H	I	
	mm									
V1.5 multiport valve with union size 1.5" / 50mm										
G18	688	538	390	454	75	239	564	130	125	
G21	732	602	497	541	90	254	576	130	125	
G25	833	703	497	621	90	310	634	130	125	
G28	903	733	497	705	90	350	675	130	125	
V2.0 multiport valve with union size 2.0" / 63mm										
G28B	903	733	497	705	90	322	744	130	195	
G32	1008	878	714	821	125	361	786	130	195	
G36	1115	1050	714	921	125	405	846	130	195	
G40	1145	1068	720	1016	150	475	900	130	195	
G44	1320	1140	800	1092	150	530	960	130	195	



Printed in Australia
By BPA

Distributed internationally by Minder Water Industries Sdn. Bhd. All rights reserved 2018.
Distributed in Australia by Minder Water Industries Pty. Ltd.
Distributed in China by Minder Water Industries (Canton) Co. Ltd.
Distributed in South-East Asia by Minder Water Industries Sdn. Bhd.