

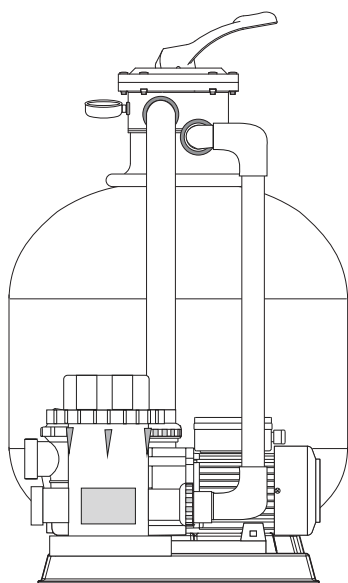

**ABOVE GROUND
FILTRATION SYSTEM**



Features & Advantages

- Elegant and compact design
- Durable fibreglass reinforced plastic casing to withstand all weather condition
- Small footprint for cost effective storage during off-peak season
- Quick installation. All pipeworks are pre-cut and ready for installation
- Quality parts and equipment manufactured by MINDER

Warranty

Multiport valve & fittings	1 year
Filter Tank	1 year
Pump	1 year
Casing	1 year

All-in-One system for easy and fast installation for all weather. MOB filtration system provides a replacement towards concrete plant-room for swimming pool system.

Operating Limits

Model	2.5bar
Maximum water temperature	43°C
Operating Pressure	2.5bar
Maximum Pressure	4.3bar

Optional Components

- MinderChlor Chlorine Generator
- Minder HydroSmart Water Management System
- Control Box for Pump, Timer & Lights
- Chlorine/ Bromine Tablet Feeder

Technical Specifications

Model	Filter Model	Pump Model	Multiport Valve Union Size		Tank Dia. mm	Filtration Area m ²	Max Flow Rate		Pump Power HP	Silica Sand kg
			Imperial	Metric			m ³ /h	lpm		
MOB550	M21	MXB			550	0.24	12	192	1.0HP-	85
MOB650	M25	Pump	1.5"	50mm	650	0.33	16	270	3.0HP	155
MOB700	M28	Series			700	0.38	19	320		210

Dimensions (mm)

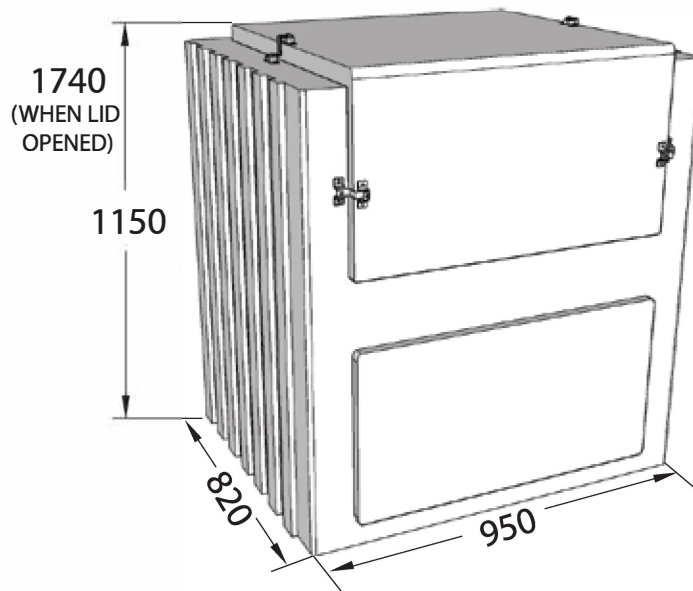

Pool Size Compatibility at 6 hr Turnover

Model	Pool Size	
	m ³	litre
MOB550	72	72,000
MOB650	96	96,000
MOB700	114	114,000

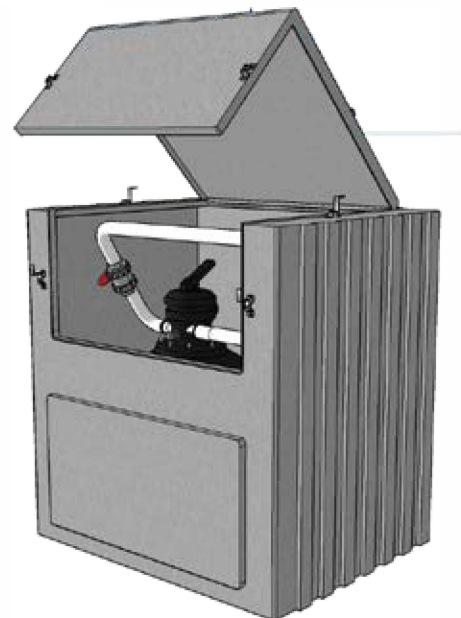



Printed in Australia
By BPA

Distributed internationally by Minder Water Industries Sdn. Bhd. All rights reserved 2018.
Distributed in Australia by Minder Water Industries Pty. Ltd.
Distributed in China by Minder Water Industries (Canton) Co. Ltd.
Distributed in South-East Asia by Minder Water Industries Sdn. Bhd.