



MRX SERIES
CENTRIFUGAL PUMP



Features & Advantages

- Best working point, large flow and high efficiency
- High quality engineered plastic body and wear resistant mechanical seal
- Motor is with high temperature bearings, long operating life with reliability
- Sales and reliable
- Enclosure class IP55 and insulation class F

Warranty

MRX Series Centrifugal Pump 1 year

Operating Limits

Maximum Water Temperature	50 °C
Ambient Water Temperature	40 °C
Maximum Pressure	0.3Mpa

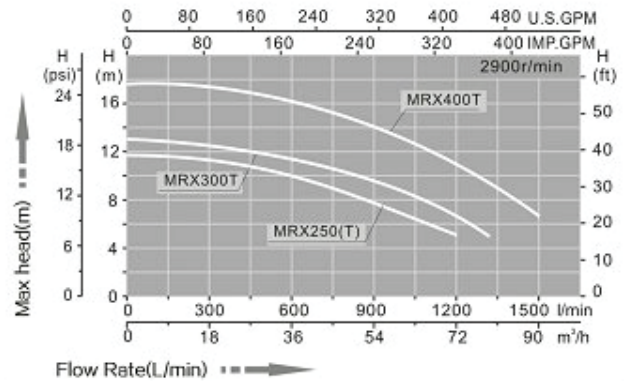

Technical Specification

Model	Code	Union Connection Size		Voltage	Frequency	Flow rate		Hmax	Power	
		Imperial	Metric			m³/h	l/min		kW	HP
MRX250T	90714			380/240		73	1210	12	2.5	3.5
MRX300T	90719	2.5"	75mm	380	50	78	1300	13	3	4
MRX400T	90720					90	1500	17.5	4	5.5

Dimensions

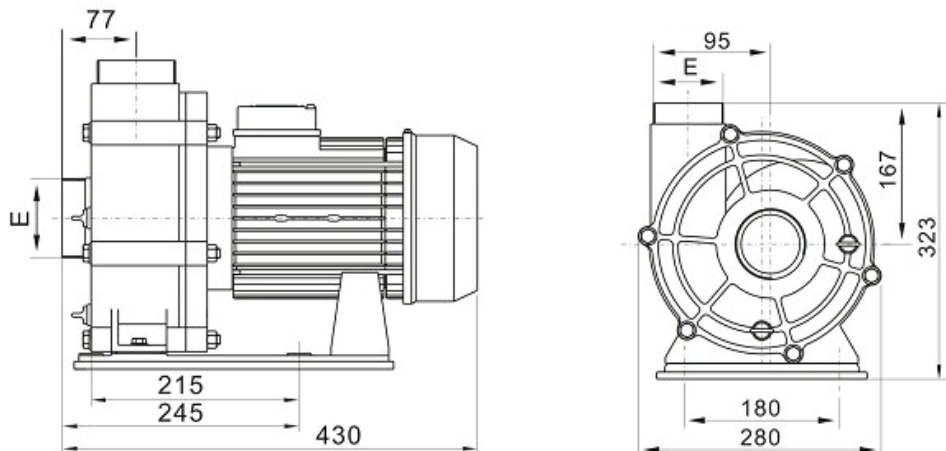



Printed in Australia
By BPA

Distributed internationally by Minder Water Industries Sdn. Bhd. All rights reserved 2018.
Distributed in Australia by Minder Water Industries Pty. Ltd.
Distributed in China by Minder Water Industries (Canton) Co. Ltd.
Distributed in South-East Asia by Minder Water Industries Sdn. Bhd.